



Rewarding Learning

General Certificate of Secondary Education

Centre Number

--	--	--	--	--

Candidate Number

--	--	--	--

Biology

Unit 3 Practical Skills

Booklet A

Foundation Tier

[GBL31]

Assessment



GBL31

TIME

2 hours.

Assessment Level of Control:

Tick the relevant box (✓)

Controlled Conditions	
Other	

INSTRUCTIONS TO CANDIDATES

Write your Centre Number and Candidate Number in the spaces provided at the top of this page.

Write your answers in the spaces provided in this question paper.

Answer **all** questions.

INFORMATION FOR CANDIDATES

The total mark for this paper is **30**.

Figures in brackets printed down the right-hand side of pages indicate the marks awarded to each question or part question.

Follow all health and safety instructions.

You may use a ruler and calculator if required.

The apparatus and materials required to complete the task(s) are provided.

For Examiner's use only	
Question Number	Marks
Task 1	
1	
Task 2	
1	
Total Marks	

Task 1: Investigating one factor needed for photosynthesis

You must wear safety glasses when carrying out this task.

A plant was placed in a dark cupboard for 48 hours.
After this time, a strip of dark card was placed over some of the leaves.
The plant was then placed in bright light for 24 hours.

Instructions

- 1 Remove one of the leaves covered with a strip of dark card from the plant.
- 2 **Answer Question 1(a) on page 3.**
- 3 Place a 250 cm³ beaker on a heatproof mat on your bench and carefully half fill the beaker with hot water.
- 4 Carefully remove the dark card from the leaf.
- 5 Using forceps, place the leaf into the beaker of hot water for one minute.
- 6 Using forceps, remove the leaf from the hot water.
- 7 Using forceps, gently place the leaf into the ethanol in the boiling tube. Take care not to break the leaf.
- 8 Immediately place the boiling tube into the beaker of hot water and leave until the green pigment has been removed from the leaf.
- 9 Using forceps or a glass rod, carefully remove the leaf from the boiling tube and dip it into the beaker of hot water for approximately 10 seconds.
- 10 Place the leaf in a Petri dish, making sure the leaf is spread out fully.
- 11 Cover the leaf with iodine solution.
- 12 **Answer Question 1 parts (b) to (g) in your booklet.**

Question 1

- (a) • Place your leaf in the box and draw around the outside of the leaf. [1]
- Draw and label the position of the dark card. [2]

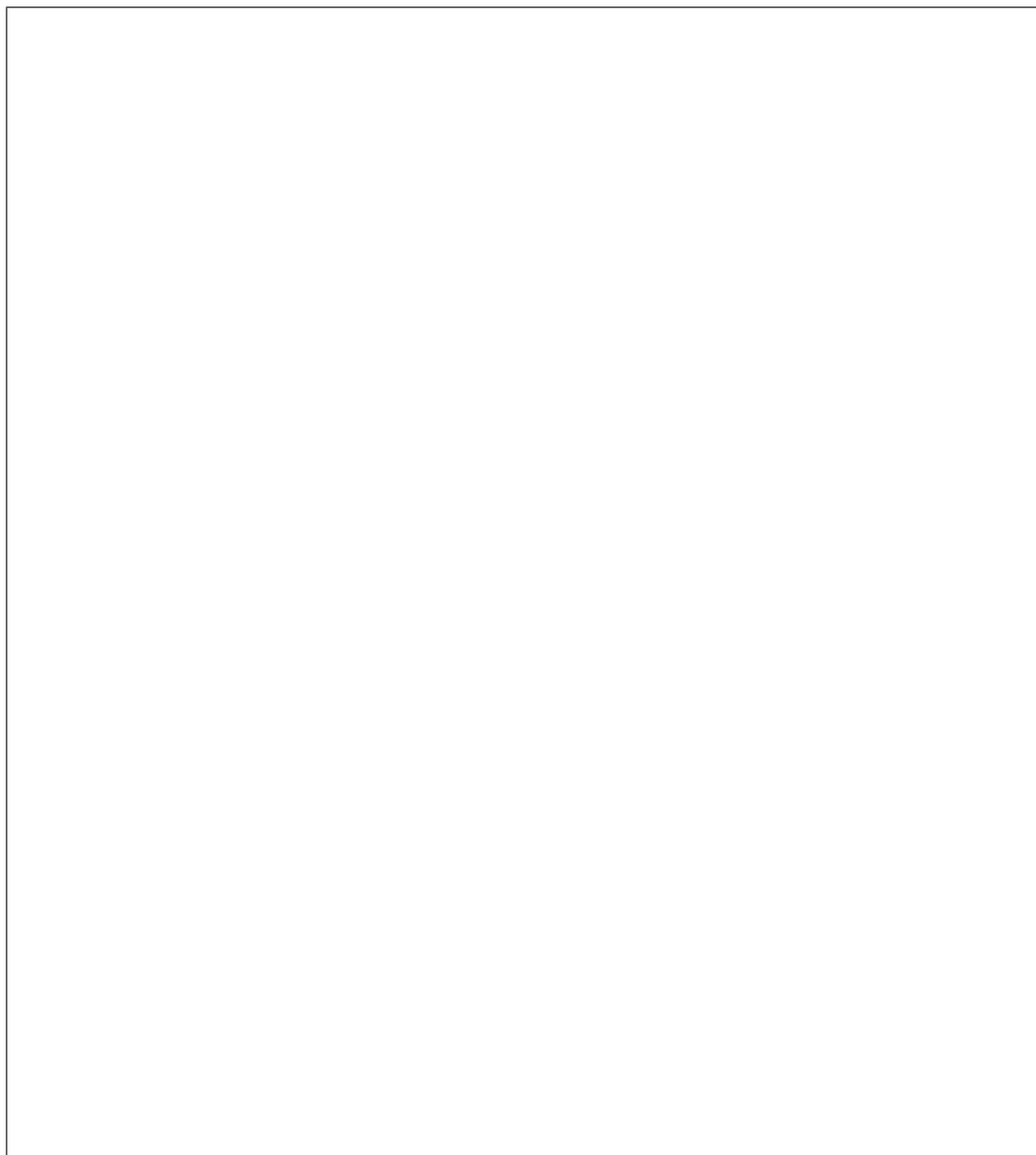

Return to step 3 of the instructions on page 2.

- (b) After testing with iodine solution describe the colour of the area of the leaf
- covered by the dark card

 - not covered by the dark card.

[2]

Examiner Only	
Marks	Remark

Task 2: Estimating the energy content of crisps

You must wear safety glasses when carrying out this task.

Instructions

- 1 Set up the apparatus as shown in the diagram.
Take care when clamping glassware.

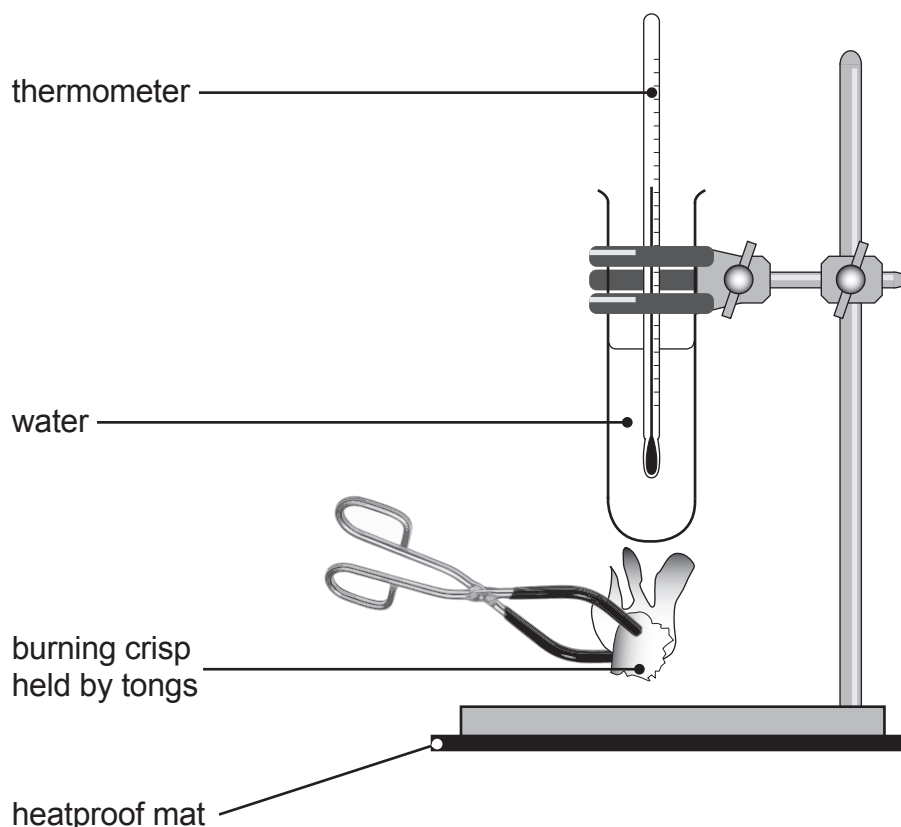

- 2 Use the measuring cylinder to add 25 cm^3 of water to the boiling tube.
- 3 Stir the water in the boiling tube using the stirring rod.
- 4 Use the thermometer to measure the temperature of the water at the start and record this in **Table 1** on page 7.
- 5 Light a Bunsen burner.
- 6 Using tongs, hold your crisp in the Bunsen flame until it starts to burn.
- 7 Immediately move the burning crisp under the boiling tube and hold it there until the crisp is completely burnt. (If the crisp goes out, relight it in the Bunsen flame and put it back under the boiling tube.)
- 8 When the crisp is completely burnt, stir the water in the boiling tube using the stirring rod.
- 9 Use the thermometer to measure the temperature of the water and record this in **Table 1** on page 7.

THIS IS THE END OF THE QUESTION PAPER

Source

Task 2.....GCSE Biology for CCEA 2nd Edition by James Napier (9780340983805) 2011 © Hodder and Stoughton Educational Limited. "Reproduced with permission of the Licensor through PLSclear."

Permission to reproduce all copyright material has been applied for.
In some cases, efforts to contact copyright holders may have been unsuccessful and CCEA
will be happy to rectify any omissions of acknowledgement in future if notified.